

MCS 920B COMPUTER TECHNICAL MANUAL

CATALOGUE NO. MCB 143

PART 2: THE ADDITIONAL STORE

CHAPTER 1: INTRODUCTION

CHAPTER 1  
INTRODUCTION  
CONTENTS

1. GENERAL
2. THE ADDITIONAL STORE (WITHOUT ACCESS CONTROL)
  - 2.1 Additional Store Units
  - 2.2 MCB 46 (Standard) MCB 47 (Military) 8192 words  
Additional Store
  - 2.3 MCB 12 (Standard) MCB 13 (Military) 16,384 words  
Additional Store
3. STORE SELECTION CONTROL SIGNALS
4. COMPOSITION OF ADDITIONAL STORES (WITHOUT ACCESS CONTROL)
  - 4.1 The 8192 words Additional Store
  - 4.2 Printed Circuit Boards of the 8192 words Additional Store
  - 4.3 The 16,384 words Additional Store
  - 4.4 Printed Circuit Boards of the 16,384 words Additional Store
  - 4.5 Extra Circuit Boards
  - 4.6 Link Boards
5. TEMPERATURE CONTROL
  - 5.1 Cooling

LIST OF FIGURES

<u>Fig.</u>	<u>Drawing No.</u>	<u>Title</u>
Fig. a	(In Text)	Additional Store Bus Bar System and Store Selection Control
Fig. B1	(322B. 7452, Sht 1)	Extra Store 8192 words 18 bit without Store Access Control, Connector and Unit Layout
Fig. B1	(322C. 7452, Sht 2)	Additional Store 16, 384 words Connector and Unit Layout

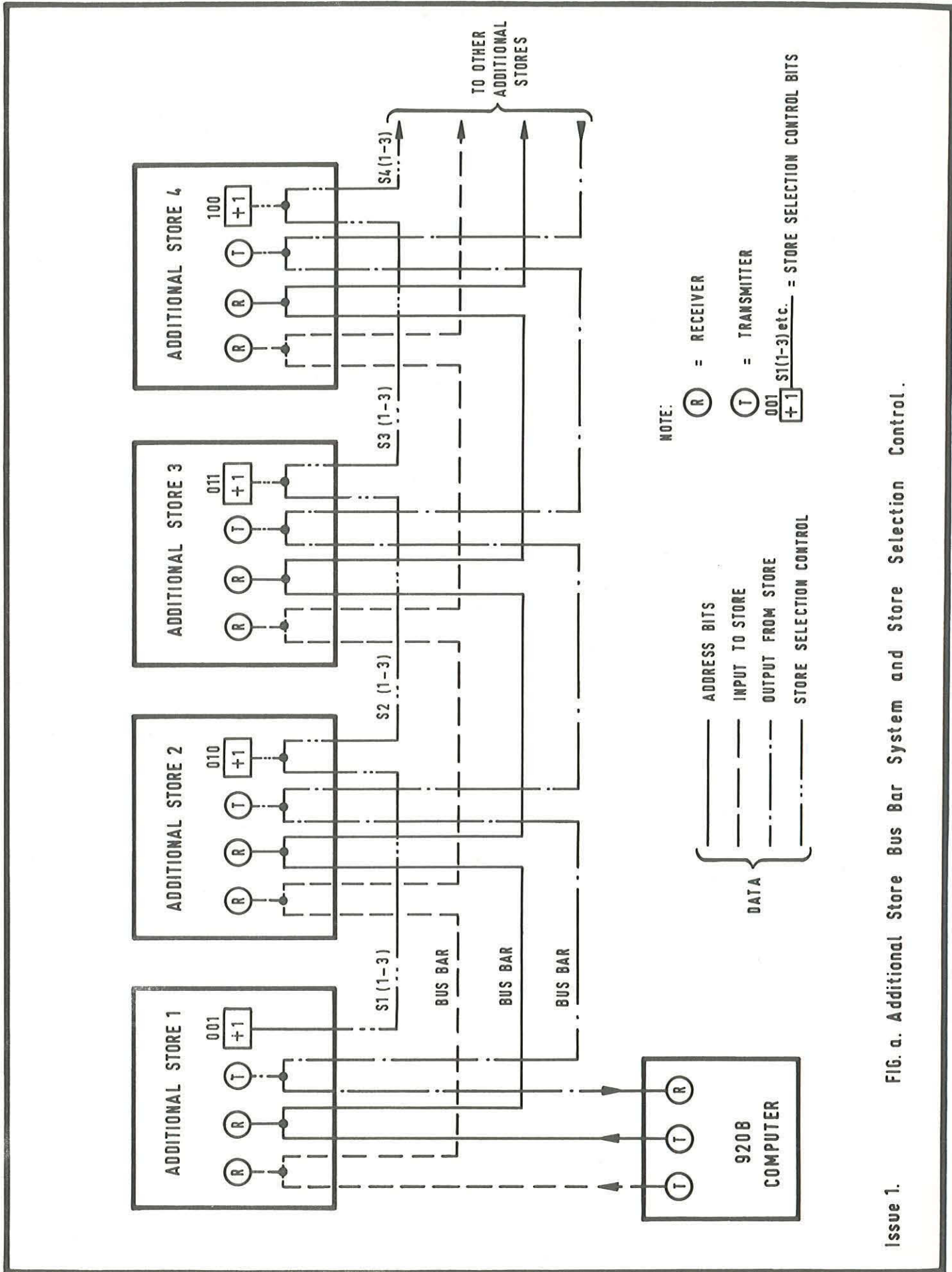

Issue 1. FIG. a. Additional Store Bus Bar System and Store Selection Control.

CHAPTER 1  
INTRODUCTION

1. GENERAL

The model 920B Computer is designed to accommodate additional store units as an extension to the internal store. The extension units MCB 12 (Standard) and MCB 13 (Military) have capacities of 16,834 words. MCB 46 (Standard) and MCB 47 (Military) have capacities of 8,192 words. Proper combinations of these units can give a total capacity of 65,536 words. The maximum possible extension of the 920B Computer comprises 3 X 16,383 word units with a 1 X 8,192 word unit. Smaller combinations may be obtained by using multiples of 8,192 word blocks.

The additional store units are connected in cascade with five multiway cables between each pair of store units, and three between the computer and the first store unit. The overall length of cable in any system is limited to 20 ft.

The operation time of additional store units is 6 microseconds, identical with the internal computer store. Instructions placed in and/or referring to the additional stores may take about 0.2 or 0.3 microseconds longer than those using the internal store. This delay being a function of cable length.

To augment the capabilities of the Additional store units an optional feature known as Access Control is added to the 8,192 word stores. This feature enables a second computer to have access to the store unit, thus allowing two computers to intercommunicate, details are given in Pt. 2, Chapters 4 and 5.

## 2. THE ADDITIONAL STORE (WITHOUT ACCESS CONTROL)

### 2.1 Additional Store Units

The additional store units are available either in standard 19" rack mounting or free standing military versions as follows:

MCB 12 16,384 words Standard

MCB 13 16,384 words Military

MCB 46 8,192 words Standard

MCB 47 8,192 words Military

### 2.2 MCB 46 (Standard) & MCB 47 (Military) 8,192 words Additional Stores

The 8k additional store comprises an entire 920B Computer store complete with its store drivers, selection circuits and temperature sensing. To achieve maximum operational speed, data and control signals are input directly from the computer without a buffer register.

The Additional Storage system is connected by a data busbar system that passes through all stores as shown in Fig. a.

Data, Address and Selection control lines are input to all Additional stores and the Selection system locates the address.

The overall computer Interconnections with Additional stores are shown in Fig. A1, Pt. 1, Chap. 1.

### 2.3 MCB 12 (Standard) and MCB 13 (Military) 16,384 words Additional Stores

The Additional store of 16,384 words consists of two 8k units within the same case. This also includes store drivers, Selection circuits and temperature sensing.

The 16k Additional store system is also connected to the computer on the busbar principle (see Fig. a).

3. STORE SELECTION CONTROL SIGNALS

The store selection control signals are transmitted between store units, to determine the addresses of each unit.

The store selection control connection to the first store unit attached to the computer is left open circuit. This condition enables the unit to accept addresses in the ranges 8, 192 to 16, 383 (8, 192 words) or 8, 192 to 24, 575 (16, 383 words) and to send store selection control signals to the second unit enabling it to select the appropriate 16, 384 or 24, 576 words and upwards and to send additional store selection control signals to the third unit and additional units in a three bit binary code.

4. COMPOSITION OF ADDITIONAL STORES (WITHOUT ACCESS CONTROL)

4.1 The 8, 192 words Additional Store

The store of 8, 192 words comprises an extra core store of 18 planes associated with several circuits for access and decode assembled on 31 plug-in units as depicted in Fig. B1, Sht 1.

4.2 Printed Circuit Boards of the 8, 192 words Additional Store

The printed circuit boards of the 8, 192 words Additional store without access control are given in Table 1.

TABLE 1

NO.	BOARD TYPE	FUNCTION
6	A-AE	Selection Diodes
6	A-EA3	Sense Amplifiers and Inhibit Drivers
1	A-EB3	Store Control
1	A-EC3	Gate Strobe and Master Drivers
5	A-ED3	Write Gates, Read Drivers and Decode

TABLE 1  
(continuation)

NO.	BOARD TYPE	FUNCTION
1	A-GZ	Temperature Stabiliser
1	A-HK	Store Select Logic
2	A-HR	Data and Address Receivers
1	A-HS	Reply Transmitters
1	A-HT	Inverters
1	A-HX	Link Board
1	A-HY	Reset Control and Interface Logic
1	A-JC	Inverters
1	A-JJ	Link Board
1	B-S1	Power ON/OFF Control

#### 4.3 The 16,384 words Additional Store

The 16,384 words Additional store consists of 55 plug-in circuit boards. Although the 16,384 words store basically comprises two 8k stores, there are several differences between the two types of store.

The 16,384 words store cannot be fitted with access control and does not use link boards.

The 16,384 words store does not have peripheral connections. A diagram of the circuit boards of this store is depicted in Fig. B1, Sht 2.

#### 4.4 Printed Circuit Boards of the 16,384 words Additional Store

The quantities, positions and functions of the 16k circuit boards are given in Table 2.



TABLE 2

NO.	POSITION	BOARD TYPE	
12	8-13, 53-58	A-AE	Selection Diodes
12	2-7, 47-52	A-EA3	Sense Amplifiers and Inhibit Drivers
2	19, 40	A-EB3	Store Control Chain
2	20, 39	A-EC3	Gate Strobe and Master Drivers
10	14-18, 41-45	A-ED3	Read and Write Gates and Drivers
2	1, 46	A-GZ	Temp. Sensing and Control
2	28, 31	A-HK	Store Select
4	22, 23, 36, 37	A-HR	Input Receivers
2	24, 35	A-HS	Reply Transmitters
2	26, 33	A-HT	J-Address Inverters
2	27, 32	A-JC	Data and Address Inverters
2	25, 34	A-HY	Reset, Control and Interface Log
1	30	B-S1	Power ON/OFF Control

#### 4.5 Extra Circuit Boards

Two additional circuit boards are supplied with the additional store. These boards plug into the central processor enabling it to access the additional store, these are:

26/A-FV Data Receivers and Transmitters

27/A-FU Data Transmitters

#### 4.6 The Link Boards

The boards 50/A-JJ and 51/A-HX are link boards, necessary because the frame and back wiring of an 8, 192 words Additional store without access control is identical to that of one with access control. For conversion to a store with access control,

certain boards are removed and others, pertaining to access control, are inserted. See Pt. 2, Chap. 4.

5. TEMPERATURE CONTROL

5.1 Cooling

The military version is enclosed, and is cooled by convection from its case.

The standard version is of open construction, and is also cooled by convection.

MCS 920B TECHNICAL MANUAL

CATALOGUE NO. MCB 143

PART 2: THE ADDITIONAL STORE

CHAPTER 2: POWER SUPPLIES AND INTERCONNECTIONS

CHAPTER 2  
POWER SUPPLIES AND INTERCONNECTIONS  
CONTENTS

1. POWER SUPPLIES (CAT. NO. MCB 21, MCB 24)
  - 1.1 Protection of Store Contents
  - 1.2 Power Supply Requirements
2. INTERCONNECTIONS
3. APPENDICES
  - APPENDIX 1 Interconnections for Plugs and Sockets
  - APPENDIX 2 Interconnections to Display Unit
  - APPENDIX 3 No. 1 32-Way Socket PL1, PL3, SKT. 8
  - APPENDIX 4 No. 2 32-Way Socket PL2, PL10, SKT. 9
  - APPENDIX 5 No. 3 61-Way Socket PL5, PL16, SKT. 17
  - APPENDIX 6 Interconnection Diagram for Additional 8, 192  
Words Store

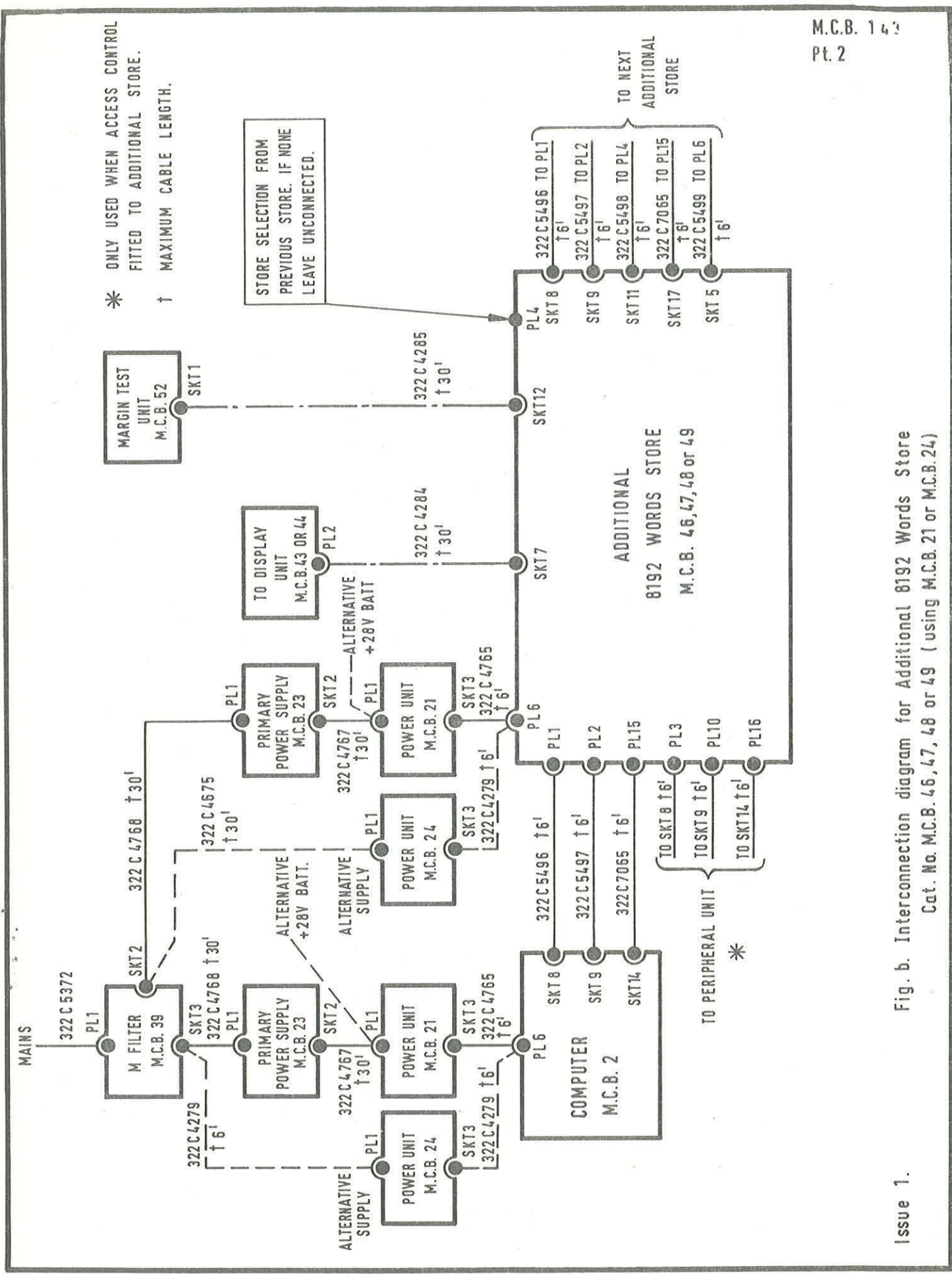

Issue 1.

Fig. b. Interconnection diagram for Additional 8192 Words Store  
Cat. No. M.C.B. 46, 47, 48 or 49 (using M.C.B. 21 or M.C.B. 24)

LIST OF FIGURES

- |          |              |   |
|----------|--------------|---|
| Fig. b.  | (In text)    | Interconnection Diagram for Additional 8, 192<br>Words Store  |
| Fig. B4. | (322B. 8087) | 920B Computer Interconnection Diagram for<br>Additional store 8, 192 words. Cat. No. MCB 46,<br>47, 48 or 49. |
| Fig. c.  | (In text)    | Interconnection Diagram for Additional 16, 384<br>Words Store.  |

## CHAPTER 2

### 1. POWER SUPPLIES. CAT. No. MCB 21, MCB 24

When extra store units are fitted, additional power units are required. A single MCB 24 computer power supply unit can be used for any size of system to a maximum of three additional 8,192 words stores. A single MCB 21 is normally required for each 8,192 words Additional store, but modifications can be made so that three additional store units can be powered. Details of power supply units are given in Part 4 of this Manual. For the interconnections see Fig. b.

#### 1.1 Protection of Store Contents

The contents of additional stores will be retained on switch-off or failure of the prime power only if a power supply unit specially designed for this purpose is used, e. g. MCB 21.

#### 1.2 Power Supply Requirements

The regulated power supplies and average currents required for additional store units of 8,192 words are as follows:

+6V d. c.  $\pm$  5% at 2A

-6V d. c.  $\pm$  5% at 0.6A

+15V d. c.  $\pm$  5% (Variable with temperature) 2.0A at 25°C

-16V d. c.  $\pm$  7% at 25mA

Allowances of 3% are permissible for margin testing.

Average power consumption of the additional store is 20 watts. Peak power consumption is 30 watts when connected to MCB 2 Computer. This may be exceeded if the store is accessed by a unit other than the MCB 2 Computer.

### 2. INTERCONNECTIONS

Interconnections between the computer and the additional

MCB 143  
Pt. 2, Chap. 2

store, and between additional store units, as well as the control and data signals are listed as a series of appendices. See Fig. B4.



APPENDIX 1

INTERCONNECTIONS FOR PLUGS AND SOCKETS

PL. 1	M-Register bits CM1-16 from computer or preceding store
PL. 2	J-Register bits CJ1-16 from computer or preceding store
PL. 3	M-Register bits PM1-16 from peripheral or preceding store used only with S. A. C.
PL. 4	Store Selection Control bits from the preceding store if any, otherwise leave unconnected
PL. 6	Power supply input from power unit or preceding store
PL. 10	J-Register bits PJ1-16. Data in from peripheral unit used only with S. A. C.
PL. 15	M-Register bits CM17, 18, + C. Store (1-x)-(18-x). Return data and control signals to computer or previous store
PL. 16	M-Register bits PM17, 18, + P. Store (1-x)-(18-x). Return data and control signals to peripheral or previous store
SKT. 5	D. C. power control to next Additional store
SKT. 7	Output of Additional store signals to Display Unit
SKT. 8	M-Register bits M1-16. Data to next Additional store
SKT. 9	J-Register bits J1-16. Data to next Additional store
SKT. 11	Store Selection control bits to next Additional store
SKT. 12	Input from margin test unit
SKT. 17	M-Register bits M17, 18, + Store (1-x)-(18-x). Return data from next Additional store

APPENDIX 2

INTERCONNECTIONS TO DISPLAY UNIT

Display Unit gives:

- \* DSP (Drive Select Peripheral) on P 6
- \* SPC (Select Peripheral Channel) on P 7
- SSI (Store Strobe Inhibit) on P 11
- \* DSC (Drive Select Computer) on P 5
- \* SCC (Select Computer Channel) on P 4
- SN<sub>1</sub> (1st Store Selection Control bit) on P 8
- SN<sub>2</sub> (2nd Store Selection Control bit) on P 9
- SN<sub>3</sub> (3rd Store Selection Control bit) on P 10

\* These signals only occur if the store is fitted with access control

APPENDIX 3

NO. 1 32 WAY SOCKET PL 1, PL 3, SKT 8

<u>FUNCTION</u>	<u>PIN</u>	<u>FUNCTION</u>	<u>PIN</u>
M1	A	M1 SCREEN	B
M2	C	M2 "	D
M3	E	M3 "	F
M4	G	M4 "	H
M5	J	M5 "	K
M6	L	M6 "	M
M7	N	M7 "	P
M8	R	M8 "	S
M9	T	M9 "	U
M10	V	M10 "	W
M11	X	M11 "	Y
M12	<u>z</u>	M12 "	<u>a</u>
M13	<u>b</u>	M13 "	<u>c</u>
M14	<u>d</u>	M14 "	<u>e</u>
M15	<u>f</u>	M15 "	<u>g</u>
M16	<u>h</u>	M16 "	<u>j</u>

32 wires

= 16 coaxial wires

All coaxial wires are isolated throughout their path. Each screen passes through a separate pin at each connector. The screens are taken to 0V at the connector of the appropriate board.

APPENDIX 4

NO. 2 32 WAY SOCKET PL 2, PL 10, SKT 9

<u>FUNCTION</u>	<u>PIN</u>	<u>FUNCTION</u>	<u>PIN</u>
J1	A	J1 SCREEN	B
J2	C	J2 "	D
J3	E	J3 "	F
J4	G	J4 "	H
J5	J	J5 "	K
J6	L	J6 "	M
J7	N	J7 "	P
J8	R	J8 "	S
J9	T	J9 "	U
J10	V	J10 "	W
J11	X	J11 "	Y
J12	<u>z</u>	J12 "	<u>a</u>
J13	<u>b</u>	J13 "	<u>c</u>
J14	<u>d</u>	J14 "	<u>e</u>
J15	<u>f</u>	J15 "	<u>g</u>
J16	<u>h</u>	J16 "	<u>j</u>

32 wires  
= 16 coaxial wires

NOTE: All coaxial wires are isolated throughout their path. Each screen passes through a separate pin at each connector. The screens are taken to 0V at the connector of the appropriate board.

APPENDIX 5

NO. 3 61 WAY SOCKET PL 15, PL 16, SKT 17

<u>FUNCTION</u>	<u>PIN</u>	<u>FUNCTION</u>	<u>PIN</u>
M17	A	M17	SCREEN B
M18	C	M18	" D
STORE 1-x	E	STORE 1-x	" F
STORE 2-x	G	STORE 2-x	" H
STORE 3-x	J	STORE 3-x	" K
STORE 4-x	L	STORE 4-x	" M
STORE 5-x	N	STORE 5-x	" P
STORE 6-x	R	STORE 6-x	" S
STORE 7-x	T	STORE 7-x	" U
STORE 8-x	V	STORE 8-x	" W
STORE 9-x	X	STORE 9-x	" Y
STORE 10-x	Z	STORE 10-x	" <u>a</u>
STORE 11-x	<u>b</u>	STORE 11-x	" <u>c</u>
STORE 12-x	<u>d</u>	STORE 12-x	" <u>e</u>
STORE 13-x	<u>f</u>	STORE 13-x	" <u>g</u>
STORE 14-x	<u>h</u>	STORE 14-x	" <u>i</u>
STORE 15-x	<u>j</u>	STORE 15-x	" <u>k</u>
STORE 16-x	<u>m</u>	STORE 16-x	" <u>n</u>
STORE 17-x	<u>p</u>	STORE 17-x	" <u>q</u>
STORE 18-x	<u>r</u>	STORE 18-x	" <u>s</u>
TR	<u>t</u>	TR	" <u>u</u>
TW	<u>v</u>	TW	" <u>w</u>
RGS	<u>x</u>	RGS	" <u>y</u>
WGS	<u>z</u>	WGS	" AA
PSC	BB	PSC	" CC

APPENDIX 5  
(continuation)

<u>FUNCTION</u>	<u>PIN</u>	<u>FUNCTION</u>		<u>PIN</u>
SSI	DD	SSI	SCREEN	EE
RESET	FF	RESET	"	GG
+24V	HH	MAINS EARTH		JJ
-24V	KK 57 wires	SPARE		LL
SPARE	MM	SPARE		NN
SPARE	PP			

See Note on Appendix 4.

MCS 920B COMPUTER TECHNICAL MANUAL

CATALOGUE NO. MCB 143

PART 2: THE ADDITIONAL STORE

CHAPTER 4: THE ADDITIONAL STORE SYSTEM WITH ACCESS CONTROL

CHAPTER 4  
THE ADDITIONAL STORE SYSTEM WITH ACCESS CONTROL  
CONTENTS

1. INTRODUCTION
  - 1.1 Construction
  - 1.2 Circuit Boards
  - 1.3 Conversion of Additional 8192 Words Stores to Access Control
2. SYSTEM FLEXIBILITY
3. ACCESSING THE STORE
4. STORE OPERATION
5. CIRCUIT BOARD LOGIC
  - 5.1 Priority Select (40/A-HO Board)
    - 5.1.1 Single Demands
    - 5.1.2 Simultaneous Demands
  - 5.2 Channel Select (41/A-HN Board)
  - 5.3 Channel Select Drivers (42/A-HQ Board)
  - 5.4 TR Regenerator (43/A-HP Board)
  - 5.5 Output Transmitters to Further Stores (A-JF Board)
    - 5.5.1 Output Transmitters (44/A-JF Board)
    - 5.5.2 Output Transmitters (45/A-JF Board)
  - 5.6 Data Transmitter to Peripheral (46/A-JD Board)



- 5.7 Input Receivers (A-HU Board)
  - 5.7.1 Input Receivers (47/A-HU Board)
  - 5.7.2 Input Receivers (48/A-HU Board)
  - 5.7.3 Input Receivers (51/A-HU Board)
  - 5.7.4 Input Receivers (55/A-HU Board)
  - 5.7.5 Input Receivers (56/A-HU Board)
- 5.8 Diplexing and Inverting (A-JC Board)
  - 5.8.1 Diplexing and Inverting (49/A-JC Board)
  - 5.8.2 Diplexing and Inverting (52/A-JC Board)
- 5.9 SSI Inputs and J14-16 Inverters (50/A-JH Board)
- 5.10 Diplexing Inverters and Transmitters (53/A-JG Board)
- 5.11 Output Data Diplexing and Computer Transmitter (54/A-JB Board)
- 5.12 Store Select Logic (57/A-JK Board)
- 6. WAVEFORMS OF THE ADDITIONAL STORES (WITH ACCESS CONTROL)
- 7. POWER SUPPLIES AND CONSUMPTION
  - 7.1 Power Supplies
  - 7.2 Supply Voltage
  - 7.3 Power Consumption
- 8. TEMPERATURE RANGE
- 9. COOLING

LIST OF FIGURES

Fig. f	(In text)	Conversion of Additional Store to include Access Control
Fig. g	(In text)	Alternative Configuration of Additional Store with Access Control
Fig. h	(In text)	Additional Store System with Access Control
Fig. i	(In text)	Selection Control for Additional Store with Access Control
Fig. j	(In text)	Waveforms of the A-HO Board)
Fig. B 6	(322C. 5483, Sht 1)	Board A-JC. Diplexing and Inverting. Pos. 52
Fig. B 7	(322C. 5470)	A-JJ Board. Link. Pos. 50
Fig. B 8	(322C. 5469)	A-HX Board. Link. Pos. 51
Fig. B14	(322C. 5731)	A-FU Board. Additional Store Cable Transmitters
Fig. B15	(322C. 5732)	A-FV Board. Additional Store Cable Receivers
Fig. B16	(322B. 7433, Sht 1)	Extra Store 8192 word 18 bit with Store Access Control. Connector & Unit Layout
Fig. B17	(322D. 7294)	920B Additional Store with Access Control Block Diagram
Fig. B18	(322D. 5417, Sht 1 and 2)	920B Additional Store with Access Control System Logic
Fig. B19	(322C. 5489)	Board A-HO Priority Select. Pos. 40
Fig. B20	(322C. 5488)	Board A-HN. Channel Select Logic. Pos. 41
Fig. B21	(322C. 5487)	Board A-HQ. Select Channel Drivers. Pos. 42
Fig. B22	(322C. 5486)	Board A-HP. T.R. Regenerator. Pos. 43
Fig. B23	(322C. 5481)	Board A-JF. Output Transmitters to Further Stores. Pos. 45
Fig. B24	(322C. 5480)	Board A-JD. Output Data to Peripheral Pos. 46

Fig. B25	(322C.5473, Sht 1 to Sht 5)	Boards A-HU. Input Receivers. Pos. 47, 45, 51, 55, 56
Fig. B26	322C.5485)	Board A-JH. SSI Inputs and J14-16 Inverters. Pos. 50
Fig. B27	(322C.5484)	Board A-JG. Diplexing Inverters and Trans- mitters. Pos. 53
Fig. B28	(322C.5482)	Board A-JB. Output Data Diplexing Com- puter Transmitter. Pos. 54
Fig. B29	(322C.5490)	Board A-JK. Store Select Logic. Pos. 57

## CHAPTER 4

### THE ADDITIONAL STORE SYSTEM WITH ACCESS CONTROL

#### 1. INTRODUCTION

The function of the Additional Store with Access Control is to provide independent channels into and out of the Additional Store so that information may be transferred autonomously. These channels have to be provided with their own complete set of addresses, information, control and status signals. Both the interfaces are identical to that between computer and store units or between additional store units. The Additional Store with Access Control is a single 8K-920B type with two identical interfaces.

##### 1.1 Construction

The Additional Store with built-in Access Control is available in Standard or Military versions:

MCB 48 8192 words Standard

MCB 49 8192 words Military

##### 1.2 Circuit Boards

The store of 8192 words with Access Control comprises a core store of 18 planes associated with several circuits for access and decode assembled on 39 plug-in units.

The standard store has been designed so that a store with Access Control will utilise identical frameworks and back wiring. This is achieved by providing a complete set of boards for each condition. In the standard version link boards are utilised to enable bus-bar highways to continue through a series of stores. When Access Control is used, signals have to be re-transmitted after diplexing. This is achieved by removing the unwanted logic boards and inserting those necessary for Access Control. See Figs. B 7 and B 8.

The circuit boards and their functions are shown in Fig. B16.  
They are tabulated below in TABLE 1.

TABLE 1  
8192 WORD STORE WITH ACCESS CONTROL. MCB 48 AND 49

No.	Board Type	Position	Function
6	A-AE	72 - 77	Selection Diodes
6	A-EA3	66 - 71	Sense Amplifiers and Inhibit Drivers
1	A-EB3	58	Store Control
1	A-EC3	59	Gate Strobe and Master Drivers
5	A-ED3	60 - 64	Write Gates, Read Gates, Decode
1	A-GZ	65	Temperature Sensing and Control
1	A-HN	41	Channel Select
1	A-HO	40	Priority Select
1	A-HP	43	TR Regenerator Channel Select Logic
1	A-HQ	42	Select Channel Drivers plus J14-16.
5	A-HU	47, 48, 51, 55 56	Data Receivers
1	A-JB	54	Output Data Inverters and Transmitters
2	A-JC	49, 52	Data and Address Inverters
1	A-JD	46	Data Transmitter (Gated)
2	A-JF	44, 45	Data Transmitter (Ungated)
1	A-JG	53	Control Signal Interface
1	A-JH	50	Control Signal Interface
1	A-JK	57	Store Select
1	B-SI	35	Power ON/OFF

Two additional plug in units are supplied with the Additional Store when ordered. These units plug into the 920B Computer enabling it to

access Additional Stores, they are:

- 1 A-FU Cable Transmitters Fig. B14
- 1 A-FV Cable Receivers Fig. B15

1.3 Conversion of Additional 8,192 words Stores to Access Control

The Additional 8192 words Store MCB 47 may be converted into an Additional 8192 words Store with Access Control, MCB 48 by removing eight printed circuit boards and introducing nineteen alternative boards.

NOTE: The backwiring is identical for each type.

The following table lists the necessary changes for the conversion of the Additional 8192 words Store to that of the Additional Store with Access Control. The board layout of the Additional Store with Access Control is given in Fig. B16.

TABLE 2

(1) Remove

No.	Board Type	Position	Function
1	A-HK	57	Store Select
2	A-HR	55, 56	Input Receivers
1	A-HS	54	Output Transmitters
1	A-HT	52	J-Inverters
1	A-HX	51	Link Board
1	A-JJ	50	Link Board
1	A-HY	53	Reset and Control Interface

TABLE 3

(2) Insert

No.	Board Type	Position	Function
1	A-JK	57	Store Select
2	A-HU	55, 56	Input Receivers
1	A-JB	54	Output Transmitters
1	A-JG	53	Logic
1	A-JC	52	Data and J-Inverters
1	A-HU	51	Receivers
1	A-JH	50	Logic
1	A-JC	49	Inverters
2	A-HU	47, 48	Input Receivers
1	A-JD	46	Output Transmitters
2	A-JF	44, 45	Transmitters
1	A-HP	43	TR Regenerator
1	A-HQ	42	Select Channel Drivers
1	A-HN	41	Select Channel
1	A-HO	40	Priority Select
1	A-HY	53	Logic

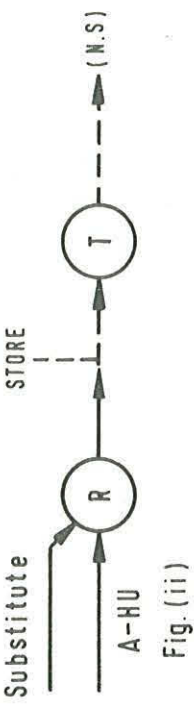

Fig. (i)

Fig. (ii)

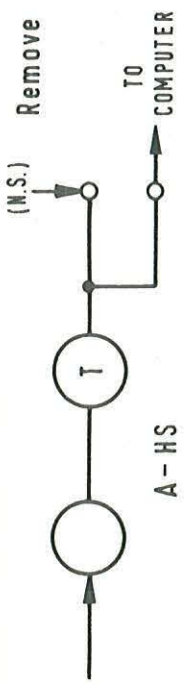

Fig. (iii)

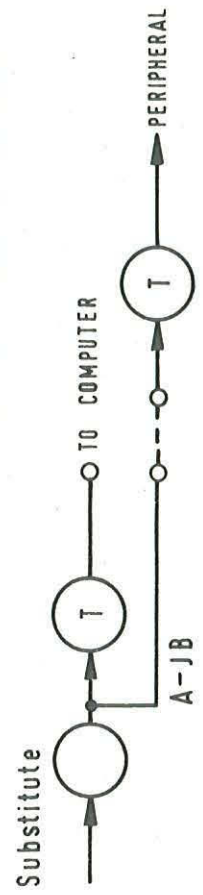

Fig. (iv)

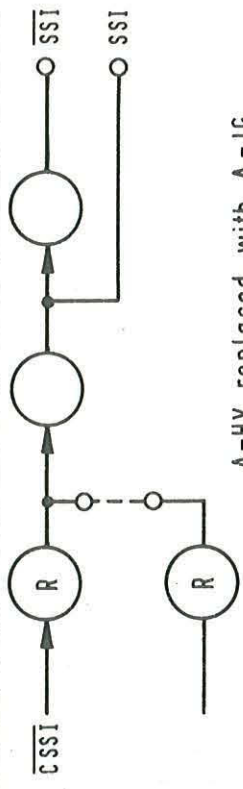

Fig. (v)

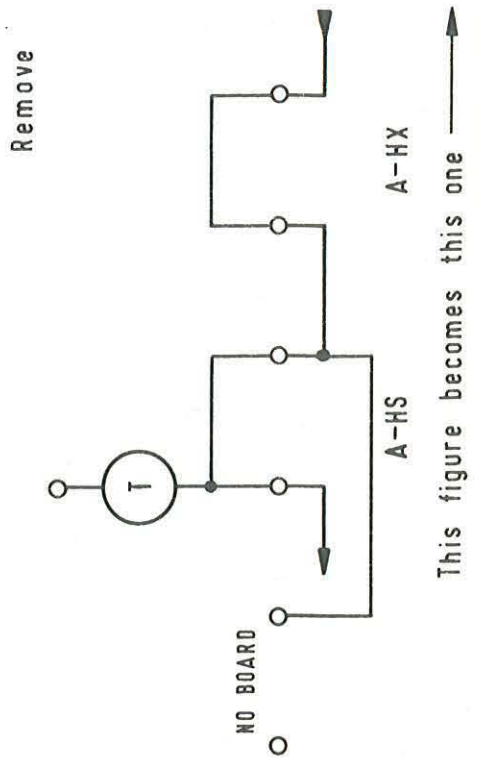
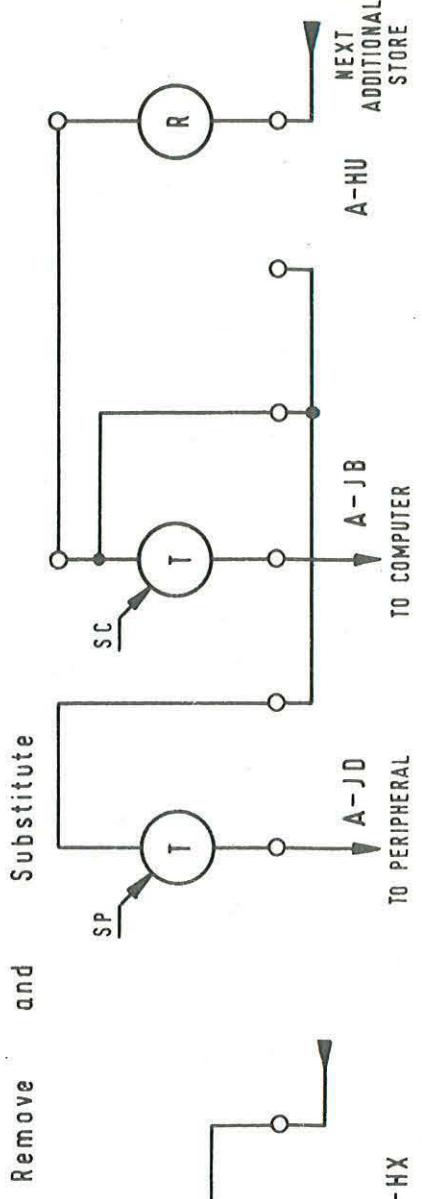

Fig. (vi)





These modifications shown in Fig. f (i-vi) are effected in the following steps:

- Step 1. Remove the 57/A-HK board and replace it with a 57/A-JK.  
This removes the Select Drivers from the unit, since with Access Control the SELECT waveform is not needed.
- Step 2. Remove the 55-56/A-HR boards and replace them with 55-56/A-HU boards. The A-HR boards are wired with links that carry Data and Address information to the next store. See Fig. f (i).  
When Access Control is used, the information to the next Additional store is routed through a transmitter, hence the link is removed on the A-HU board as shown in Fig. f (ii).
- Step 3. Remove the 54/A-HS board and replace it with a 54/A-JB board. The 54/A-HS board has links that enable information from the next Additional Store to reach the Computer. These are not needed with Access Control since reply signals are passed through a receiver in the store with Access Control. This is shown in Fig. f (iii). The A-JB board routes the information to the Computer and through a transmitter to the peripheral. See Fig. f (iv). This achieves a fan-out of two destinations.
- Step 4. Remove the 53/A-HY board and replace it with a 53/A-JG board. This operation achieves steps 2 and 3 of the waveform SSI, RESET,  $\overline{WGS}$  and  $\overline{RGS}$  adding two inverters for SSI. This is shown in Fig. f (v).
- Step 5. Remove the 52/A-HT board and replace it with a 52/A-JC board. This modifies the routing of  $\overline{TR}$  to the 43/A-HP board instead of to the A-EB3 board.

- Step 6. Remove the 51/A-HX link board and replace it with a 51/A-HU board. This inserts Data Receivers from a preceding store where a link board was originally placed. This is shown in Fig. f (vi).
- Step 7. Remove the link board 50/A-JJ and replace it with a 50/A-JH board. This achieves step 6 for SSI, RGS, WGS and inserts the Special Reset Logic required. It also introduces transmitters for WGS, and RGS to the Peripheral Unit.
- Step 8. All other units or boards to be inserted introduce the extra logic required for the peripheral unit and the Additional Store Access Control such as the following:

47-48/A-HU	Input Receivers
46/A-JD	Data Transmitters to Peripheral
44-45/A-JF	Output Transmitters to Further Stores
49/A-JC	Diplexing and Inverting
43/A-HP	TR Regenerator
42/A-HQ	Select Channel Drivers
41/A-HN	Channel Select Logic
40/A-HO	Priority Select

## 2. SYSTEM FLEXIBILITY

The Additional Store with Access Control gives independent Access to Additional Store units connected to the computer.

This configuration allows the transfer of data (to or from a peripheral device) to be executed concurrently with central processor operations.

In this system the data channels of an extra store with Access Control will only be occupied if a store on the remote side of the Access Control unit to the computer or the store with the Access Control unit itself is accessed. This is shown in Fig. g (i).

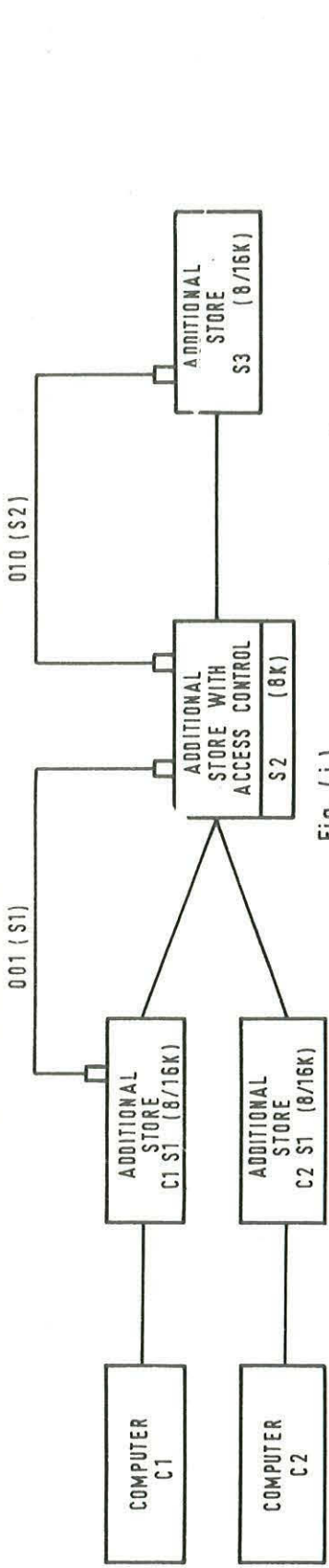

Fig. (i)

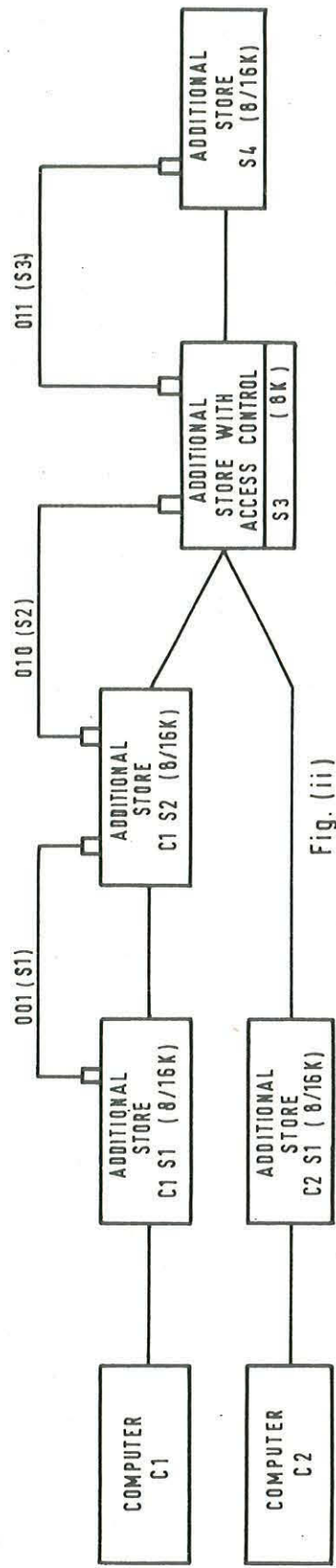

Fig. (ii)

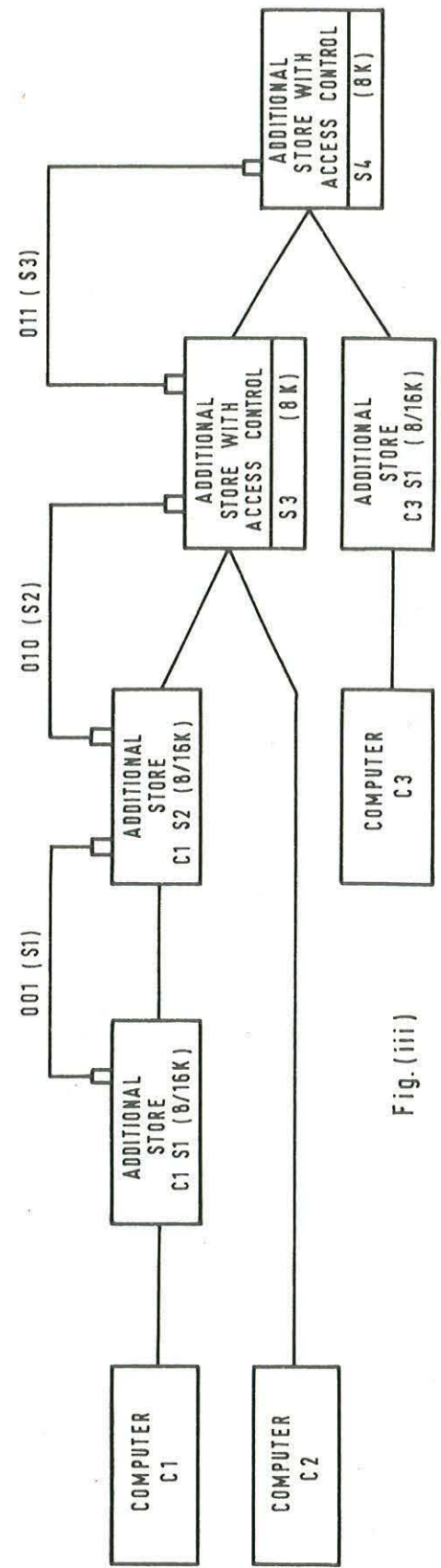

Fig. (iii)

Fig. 9. Alternative Configurations of Additional Store with Access Control

If computer C1 accesses its store C1S1 the access control S2 will remain open to demands from C2. If either computer accesses S3, then the other can only access its store S1 i. e. C1S1 or C2S1 at the same time. Thus the Additional Store with Access Control may be utilised as a common extra store for two computers. In such installation the second computer is connected to the peripheral input of the store.

In cases where each of these installations have Additional storage and the amounts differ, the store selection signals for the shared store unit must be connected to the last unit of the larger store system. This is shown in Fig. j (ii) where computer C2 is connected to the Additional store C2S1, computer C2 cannot access store C1S2 but can access store blocks S3 and S4. However computer C1 can access store blocks C1S1, C1S2, S3 and S4. In Fig. g (iii) computer C2 can only access stores S3 and S4, while C3 can access C3S1 and S4.

The definition of a store block as S1, S2, S3 etc., is achieved by means of the store selection control bits (Sn). In all systems involving more than one computer with common blocks of storage, one of the computers is connected to the peripheral input of the store.

If one or more peripheral units require access to the store, Additional Store Access Control units may be connected in cascade to give the necessary number of channels. Additional stores of 16,384 words cannot be used with a peripheral.

Alternatively, an A.D.T. (Autonomous Data Transfer) unit may be connected to the peripheral input to the store thus giving access to a single store by several peripheral devices.

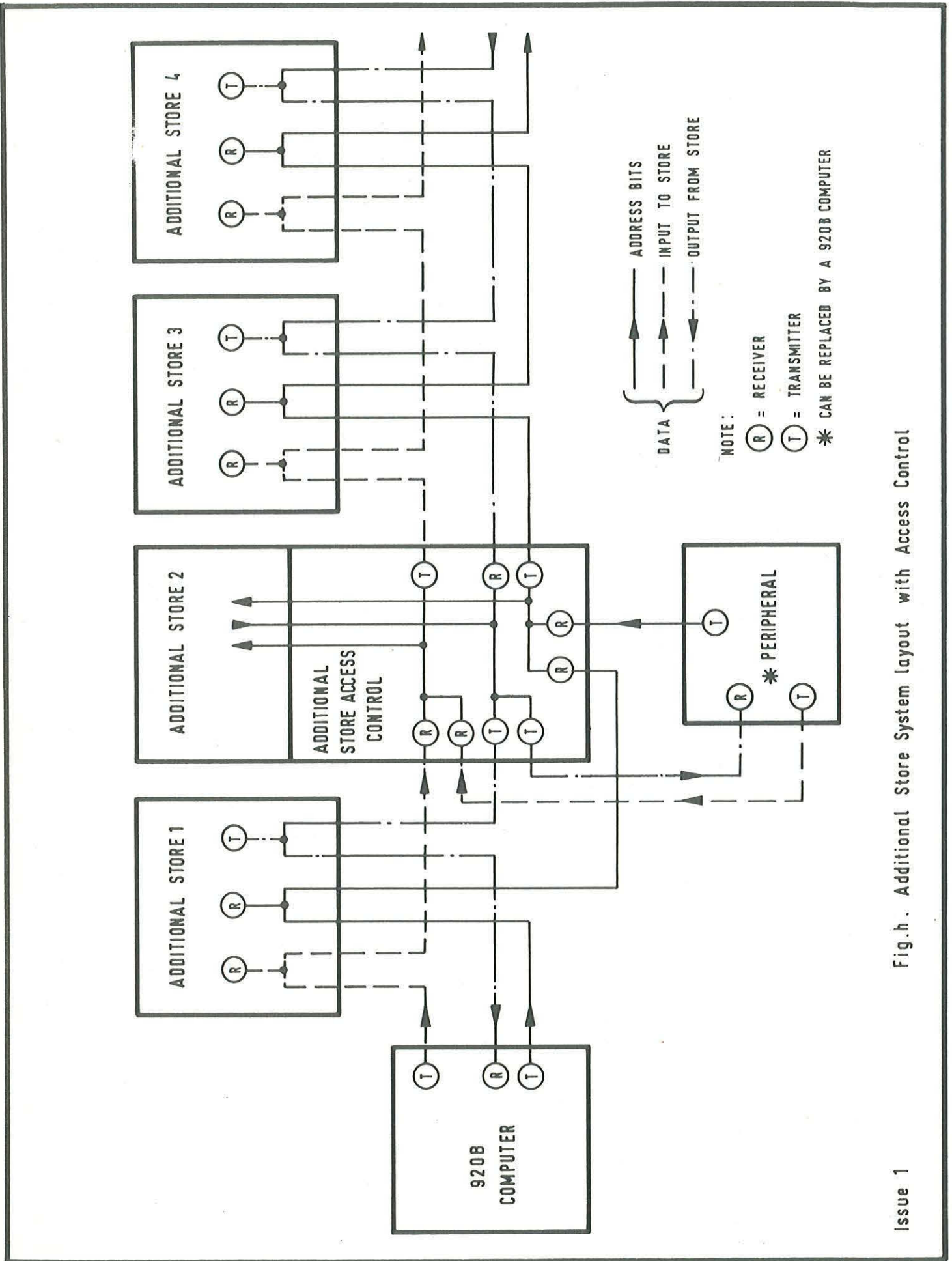

Fig.h. Additional Store System layout with Access Control

Issue 1

#### 4. ACCESSING THE STORE

The Additional Store with Access Control presents two computer type interfaces to associated equipment and may be accessed from either channel. Simultaneous demands are therefore met by assigning a higher priority to the peripheral channel so that in the event of a large number of simultaneous demands they are processed alternately.

A simplified diagram of the additional store system with Access Control is given in Fig. h.

A store with Access Control breaks the bus-bar of information by the insertion of receivers and transmitters relaying information from either of the two channels on to other Additional stores. Therefore this type of store can only be accessed by the Access Control Logic which routes the demand either to itself or to a store block with a different address. When this is so the data is regenerated and passed on to the next store. When this is not so the bus-bar is left free to demands on the other channel.

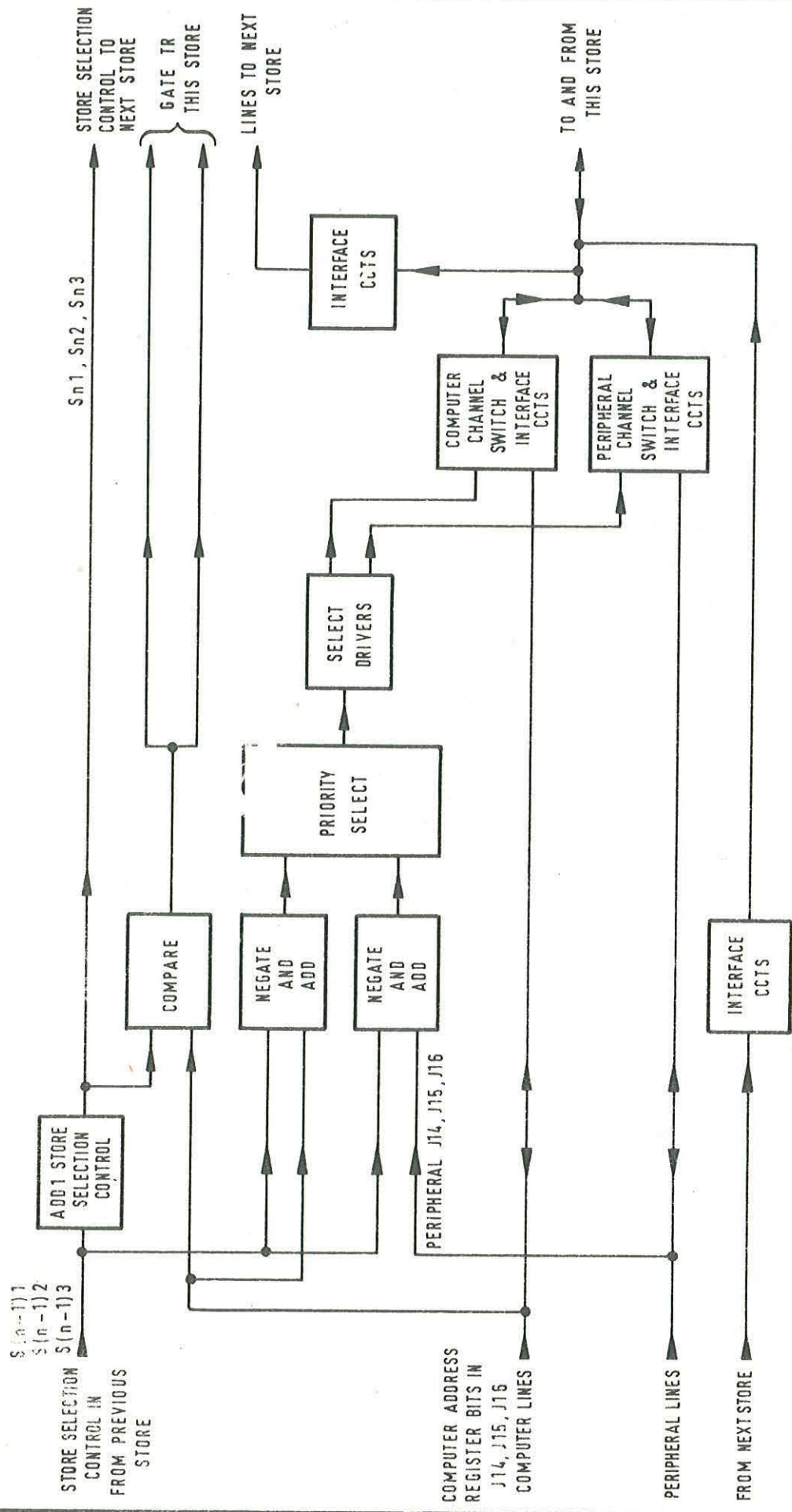

Fig. i. Selection Control for Additional Store with Access Control.

#### 4. STORE OPERATION

The receipt of a waveform either from the computer or peripheral channel will initiate store operation in any section of the store. This gates the address, information and control signals from the initiating unit to that store. The information and status signals are thus routed from the store back to the unit. A waveform received from the other unit (peripheral or computer) is held until the previous store cycle is complete. Priority is given to the peripheral so that during periods of simultaneous demands word transfers can be effected between peripheral and Additional stores during computation. On such occasions the transfers are interleaved with computer accesses to the Additional Store. (This process is known as 'cycle stealing'). Computer accesses to its internal store or to preceding storage may take place simultaneously with peripheral transfers. A simplified block diagram of the Selection Control for Additional Store is given in Fig. i. It shows the relationship between the Store Selective Control bits and the J address bits.

When either the computer or the peripheral unit accesses the Additional Store, it sets up its data and address lines to the appropriate numbers and sends out a TR pulse. In the Additional Store, the three most significant bits (J14-16) are compared with the three store Selection Central bits (Sn1, 2, 3). Coincidence of these signals determines if the store in question is being accessed. If the store with Access Control or any store on its remote side from the computer is being accessed, then information is gated from the accessing channel to any further stores.

If a store placed between the computer and the store with Access Control is being accessed then no action is taken and the remote data bus-bar is left free to access from the other channel.

To permit the store operation described above the Access Control unit includes the functions of a diplxer allowing two units to access an additional store. Confusion is prevented by naming one channel the



Computer Channel and prefixing its waveforms with a 'C'. The other channel is named the Peripheral Channel and its waveforms prefixed by a 'P'. A comprehensive block diagram of the Additional Store including the interface logic is given in Fig. B17. This shows the signal paths to and from the computer, peripheral, core stack and next Additional store. The System Logic drawing is depicted in Fig. B18.

## 5. CIRCUIT BOARD LOGIC

The system logic of the Additional Store with Access Control is given in Fig. B18, Shts 1 and 2. This drawing depicts the board logic in relation to other boards.

### 5.1 Priority Select (40/A-HO Board)

The function of the A-HO is to allocate priority to demands from either channel and to generate the waveforms from which the interface gating signals are produced. The logic diagram of the 40/A-HO board is given in Fig. B19. The input waveforms are SCC and SPC from the 41/A-HN board, the strobe S4 from the 43/A-HP board and RESET from the 50/A-JH board. Switching is effected by S1, S4,  $\overline{S4}$ , S5,  $\overline{\text{RESET}}$ , RCC and RPC. The outputs are RCC, RPC,  $\overline{\text{DSC}}$  and  $\overline{\text{DSP}}$  which are routed to the 43/A-HP board

#### 5.1.1 Single Demands

A demand on either the low or high priority channel (defined as the computer or peripheral channels respectively) takes the form of either SCC or SPC coming true. (See Sec. 5.1.2 for simultaneous demands).

The appearance of SCC or SPC sets up the intermediate stasiser on the pertinent channel and a single shot pulse train producing S1. S1 gates the information into the final stasiser setting up the signals  $\overline{\text{DSC}}$  or  $\overline{\text{DSP}}$  and RCC or RPC. The signals  $\overline{\text{DSC}}$  and  $\overline{\text{DSP}}$  control the gating of the interface.

RCC and RPC are used on the A-HU board to control the resetting of the channels.

On the completion of the store cycle,  $\overline{S4}$  is generated from the trailing edge of WGS. This resets the intermediate stasisiser on the channel that has just been accessed the store and restarts the single shot pulse train to allow any additional demands in. It also generates  $\overline{S5}$  which resets the final stasisiser on the channel that has just obeyed a demand. A timing diagram of a single demand is given in Fig. j(i).

#### 5. 1. 2 Simultaneous Demands

If two simultaneous demands occur (defined as being within 100 nseconds of one another), the same sequence of events take place and the two intermediate stasisisers are set-up. However, the presence of a demand on the peripheral intermediate stasisiser prevents S1 from gating the computer demand into the computer channel final stasisiser. The resulting effect is that only the peripheral demand is acknowledged.

The computer demand, however, is stored in the intermediate stasisiser in the computer channel, and is gated into the final stasisiser by the S1 produced at the end of the peripheral channel store cycle.

A timing diagram of the sequence of events that occur where two demands arise simultaneously are given in Fig. j(ii).

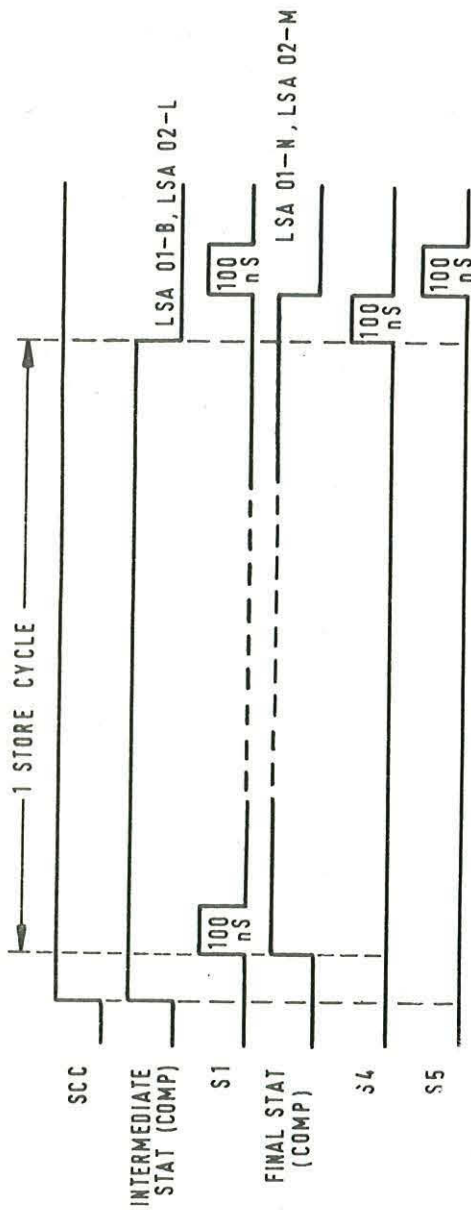

Waveforms for Single Demand on A-H0 Board Fig.(i)

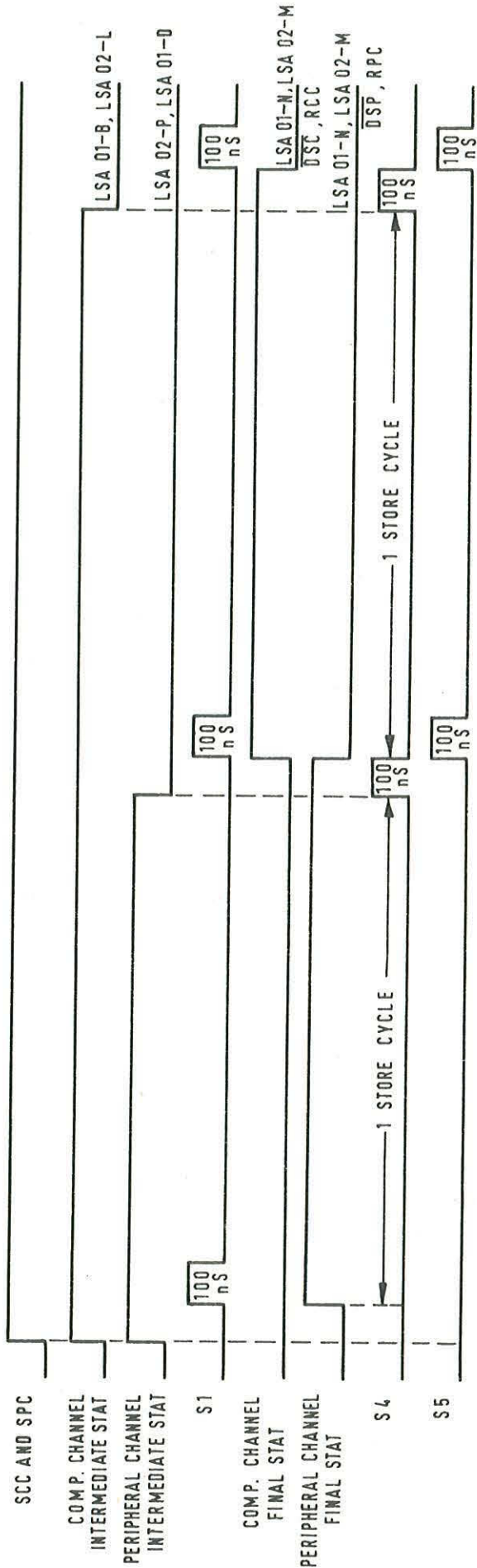

Waveforms of Simultaneous Demands on the A-H0 Board Fig. (ii)

Fig. j. Waveforms of the A-H0 Board ( Priority Select Logic).

### 5.2 Channel Select (41/A-HN Board)

The logic circuits of the A-HN board are depicted in Fig. B20. These circuits determine the channel on which an access is to be made.

In this board the Store Selection Control bits are compared with the three most significant J bits of each Channel (CJ14-16, PJ14-16) and generate either Select Computer Channel (SCC) waveforms or Select Peripheral Channel (SPC) or both and input to the A-HP and A-HO boards.

### 5.3 Channel Select Drivers (42/A-HQ Board)

The A-HQ board contains the Select Channel Drivers and the logic diagram is given in Fig. B21.

The A-HQ board fans out the channel select signals Select Computer (SC) or Select Peripheral (SP) from three lines to six lines each from the A-HP board.

It also routes the three most significant bits from the selected channel to any other Additional Stores in the system.

### 5.4 TR Regenerator Board (43/A-HP Board)

The main function of the TR board is to regenerate the TR signal. A logic drawing of the A-HP board is given in Fig. B22.

The TR signals from either or both channels are stashed by the A-HP board. They are stored to allow time for priority selection. On the allocation of priority a TR signal is regenerated from the appropriate channel. If simultaneous demands occur on both channels, the TR waveform from the unused channel is stored or delayed for one cycle.

The signals Drive Select Computer (DSC) or Drive Select Peripheral (DSP) are taken from the A-HO board and fanned out into three lines routing them to the A-HQ board.

The signal S4 is generated from the trailing edge of WGS and is used to reset the stasisiser of the channel to which the previous cycle was allocated.

#### 5.5 Output Transmitter to Further Stores (A-JF Board)

The function of the A-JF board is to transmit information from the channel which is accessing either the store with Access Control or Additional Stores to further Additional Stores

##### 5.5.1 Output Transmitters (44/A-JF Board)

The logic diagram of a 44/A-JF board is given in Fig. B23, Sht 2.

This board consists of 19 two input transmitters (LSA 22) utilising only one input. The waveforms J1-J16, RESET, TR and TW enter the board and are output in the same phase.

##### 5.5.2 Output Transmitters (45/A-JF Board)

The logic diagram of the 45/A-JF board is given in Fig. B23, Sht 1.

The 45/A-JF board is identical to the 44/A-JF board. The signals processed are different being M1-M18 and SSI.

#### 5.6 Data Transmitter to Peripheral (46/A-JD Board)

The logic diagram of this board is given in Fig. B24. The output data from either the store with Access Control or further stores are routed to the peripheral unit via this board. The routing is achieved by Select Peripheral 1 (SP1).

The A-JD board comprises 18 LSA 22 transmitters, this gives improved loading at the output. The input waveforms store (1-x to 18-x) are gated by SP1. They are output in the same phase as at the input.

## 5.7 Input Receivers (A-HU Board)

The A-HU board consists of a number of twin input NAND gates and gated receivers. All A-HU boards are identical and may be interchanged but the signals processed by the boards are different at each position.

### 5.7.1 Input Receivers (47/A-HU Board)

The logic diagram of the 47/A-HU board is given in Fig. B25, Sht 5.

The input waveforms PJ1-16 are input and gated by SP6. PTR and PTW are also input. The outputs are inversions of the inputs with the exception of SP6 which is not output.

### 5.7.2 Input Receivers (48/A-HU Board)

The logic diagram of the 48/A-HU board is given in Fig. B25, Sht 4.

The inputs PM1-18 are gated by SP5. The outputs are inversions of the inputs with the exception of SP5 which is not output.

### 5.7.3 Input Receivers (51/A-HU Board)

The logic diagram of the 51/A-HU board is given in Fig. B25, Sht 3.

This board receives the waveforms STORE (1-x to 18-x) from the Additional Store. The outputs are inversions of the inputs. The output of this board is input to the 54/A-JB board.

### 5.7.4 Input Receivers (55/A-HU Board)

The logic diagram of the 55/A-HU board is given in Fig. B25, Sht 2.

The logic circuits of the board receive the waveforms CJ1-16 plus CTR and CTW from the computer. The outputs are  $\overline{\text{CTR}}$  to the 43/A-HP board,  $\overline{\text{CJ1-13}}$ ,  $\overline{\text{CTR}} + \overline{\text{CTW}}$  to the 52/A-JC board,  $\overline{\text{CJ14}}$ ,  $\overline{\text{CJ15}}$ ,  $\overline{\text{CJ16}}$  to the 53/A-JG board.

#### 5.7.5 Input Receivers (56/A-HU Board)

The logic diagram of the 56/A-HU board is given in Fig. B25, Sht 1.

This board receives the waveforms CM1-18 which are gated by SC5. The outputs are inversions of the input with the exception of SC5 which is not output. The C Data output is input to the 49/A-JC board.

### 5.8 Diplexing and Inverting (A-JC Board)

The function of the A-JC board is that of a Data Inverter and Diplexer. The output of this board consists of the same signals as input, in addition to an equal number of signals that are inversions of the input. The A-JC board is also used in the Additional Store without Access Control.

#### 5.8.1 Diplexing and Inverting (49/A-JC Board)

The logic diagram of the 49/A-JC board is given in Fig. B 6, Sht 2.

This board receives C Data from the 56/A-HU board or P Data from the 48/A-HU board in the form of M1-18.

#### 5.8.2 Diplexing and Inverting (52/A-JC Board)

The logic diagram of the 52/A-JC board is given in Fig. B 6, Sht 1.

The input waveforms to this board are either  $\overline{\text{PJ1-13}} + \overline{\text{PTR}}$ ,  $\overline{\text{PTW}}$  from the 55/A-HU board or  $\overline{\text{CJ1-13}} + \overline{\text{CTR}}$ ,  $\overline{\text{CTW}}$  from the 57/A-HU board.

5.9 SSI Input and J14-16 Inverters (50/A-JH Board)

The A-JH board (together with the A-JG board) provides the control signal interface between a previous Additional Store and the computer or a peripheral unit, Fig. B26 refers.

Peripheral Address bits  $\overline{PJ14}$ ,  $\overline{PJ15}$  and  $\overline{PJ16}$  are inverted via LSA 44 high threshold inverters to provide PJ14, PJ15 and PJ16. A further stage of inversion (in parallel with the output of the LSA 44) provided by LSA 01 gives  $\overline{PJ15}$  and  $\overline{PJ16}$  ( $\overline{PJ14}$  is not used). The peripheral address bits and their bars are routed to the Select Channel Drivers (A-HQ) and Channel Select decode logic (A-HN).

PSSI from the peripheral unit is gated with SP2 by LSA 23 to produce  $\overline{PSSI}$  to the 53/A-JG board.

WGS and RGS from the next Additional Store are routed via LSA 23 receivers to the A-JG board to produce CRGS and CWGS if SC2 is present and re-input to the A-JH board to produce PRGS and PWGS if SP2 is present.

$\overline{C\ RESET}$  (Computer Reset) is input to an LSA 44 high threshold inverter, the parallel outputs of which ( $\overline{RESET}$ ) are buffered by two LSA 15 and routed to Store Control (A-EB3), Channel Select (A-HP), Store Select (A-JK) and Priority Select (A-HO) boards, Fig. B18 refers.

5.10 Diplexing Inverters and Transmitters (53/A-JG Board)

The logic circuits of this board invert and double the number of waveforms input. The logic diagram of the A-JG board is given in Fig. B27.

The waveforms  $\overline{CJ14-16}$  are input from the 55/A-HU board routing CJ14-16 to the 41/A-HN and 42/A-HQ board and CJ14-16 to the 41/A-HN and 57/A-JK boards. CSSI and C RESET enter NAND gates and



are strobed by SC2 with  $\overline{\text{C RESET}}$  output to the 50/A-HJ board and to the store.  $\overline{\text{PSSI}}$  input from the 50/A-JH board also gates CSSI and the output is input to the 59/A-EC3 and 45/A-JK boards.

The Write and/or Read gating waveforms  $\overline{\text{WGS}}$  and  $\overline{\text{RGS}}$  input from the store are selected by SC2 input from the 42/A-HQ board and transmitted to the computer.

#### 5.11 Output Data Diplexing and Computer Transmitter (54/A-JB Board)

The logic circuits of this board execute the functions of a data diplexer and transmitter. Each input signal to this board gives two signals identical to the input waveform. The only signal not output is the common gating waveform SC1. The logic diagram of the 54/A-JB board is given in Fig. B28.

The waveforms STORE (1-x to 18-x) are input from the further stores, the 51/A-HU board and the store. Selection is effected by the waveform SC1 which is output from the 42/A-HQ board. One output waveform P STORE (n-x) is input to the 46/A-JD board. The other output C STORE (n-x) is input to the computer.

#### 5.12 Store Select Logic (57/A-JK Board)

The logic diagram of the 57/A-JK board is given in Fig. B29. The waveforms input to this board are J14-16 and S(n-1)1, S(n-1)2 and S(n-1)3. The outputs are Sn1, Sn2 and Sn3 input to the Additional Store. Outputs are SSTR and SSTW which are input to the store.

This board is similar to the 57/A-HK board with the exception that strobes 1 through 4 are omitted (not being necessary to the store with Access Control). A full description of the A-HK board is given in Sec. 6.2, Part 2, Chapter 3.

6. WAVEFORMS OF THE ADDITIONAL STORES (WITH ACCESS CONTROL)

S(n-1)1	
S(n-1)2	Store Selection Control bits from previous store
S(n-1)3	
Sn1	
Sn2	Store Selection Control bits of this store (defining the Store block No. of this store)
Sn3	
SELECT 1	
SELECT 2	Used to trigger interface in Additional Store
SELECT 3	
SELECT 4	
$\overline{\text{SSTW}}$	Store Select $\overline{\text{TW}}$
$\overline{\text{SSTR}}$	Store Select $\overline{\text{TR}}$
SCC	Select Computer Channel
SPC	Select Peripheral Channel
DSC	Drive Select Computer
DSP	Drive Select Peripheral
SC1	} Result of negate and add with Additional Store Access Control
SC2	
SC3	
SC4	
SC5	
SC6	

SP1	}	Selects peripheral signal lines as a result of priority allocation	
SP2			
SP3			
SP4			
SP5			
SP6			
RCC	}	Reset Computer Channel	} Produced as a result of priority allocation. They clear the accessed channel at the end of a store cycle
RPC			
S1	}	Used for setting bistables in priority select logic	
S2			
S3			
S4		Used for resetting certain bistables. Produced by the backedge of WGS.	

## 7. POWER SUPPLIES AND CONSUMPTION

### 7.1 Power Supplies

The Additional Store with Access Control can be powered by a computer power supply unit MCB 24 or MCB 21. Additional Store units accessible only to the computer cannot share a power supply unit with an Access Control store unit. Each Access Control store unit requires its own individual power supply unit and this may drive up to two additional stores provided that they are not interposed between the computer and the Store with Access Control. For details in Power Supply Units see Part 4 of this Manual.

7.2 Supply Voltage

The following supply voltages are required:

- +6V d. c.
- 6V d. c.
- +15V d. c. (varies with temperature)
- 16V d. c.
- 250V 50 c/s a. c.

7.3 Power Consumption

The power consumption of the Additional Store with Access Control is tabulated in Table 4.

TABLE 4

Voltage	Current Quiescent	Mean During Cycle	Peak During Cycle
+6V d. c.	2.6A	2.9A	3.4A
- 6V d. c.	700mA	1.1A	1.3A
+15V	-	1.83A	1.3A
- 16V		30mA	
a. c.		18VA	

Power Consumption is Min. 15W. Max. 25W.

8. TEMPERATURE RANGE

The Additional Store will operate reliably in an ambient temperature of  $-10^{\circ}\text{C}$  to  $+55^{\circ}\text{C}$ . Sufficient warm-up time must be allowed before switching-on after storage at temperature below  $-10^{\circ}\text{C}$ .

Although the internal store of the computer is equipped with a store heater, the Additional Stores are not so equipped, and will not start at temperatures below  $-10^{\circ}\text{C}$ .

9. COOLING

The Military unit is totally enclosed being cooled by convection from its case.

The Standard versior is of open construction being also cooled by convection.

MCB 143  
Pt. 3, Chap. 1

MCS 920B COMPUTER TECHNICAL MANUAL

CATALOGUE NO. MCB 143

PART 3: PAPER TAPE EQUIPMENT

CHAPTER 1: INTRODUCTION